



Transformer Nitrogen Systems Universal Instructions

GENERAL INFORMATION

The positive pressure nitrogen gas pressurizing system protects the transformer oil in the main tank from both oxidation and moisture absorption, and maintains the high quality of the insulating oil.

DESCRIPTION

The system consists of a nitrogen gas supply cylinder with its own control valve, a supply pressure gauge, a three stage pressure reducing assembly and the piping and valves which control the flow of gas to and from the tank. The system includes connection points for low gas supply, high tank pressure, and low tank pressure alarms.

When the system is correctly set-up and operating it will maintain transformer tank pressure at 0.5 psi minimum and 5.0 psi maximum. If the tank pressure drops below 0.5 psi, nitrogen gas flows from the supply cylinder through the reducing valve assembly and into the tank until the 0.5 psi pressure is restored. Should tank pressure rise above 5.0 psi, a relief valve opens to bleed off the excess pressure. Alarms are actuated when gas pressure at the supply cylinder drops below 200 psi, when transformer tank pressure rises above 5.5 psi, and when tank pressure drops below 0.2 psi.

Inert air systems are shipped with the system tested and fully operational. To make certain that all components are functioning properly, the system should be checked according to the following schedule:

- SUPPLY CYLINDER PRESSURE
- TRANSFORMER TANK PRESSURE
- TRANSFORMER OIL TEMPERATURE
- AMBIENT TEMPERATURE

1st Week: Check daily (minimum)

2nd-4th Week: Check once per week (minimum)

After 4th Week: Check as required by utility maintenance program and recorded with dates and times noted. Readings which show consistency indicate the equipment is operating properly.

CAUTION: Verify weekly during 1st 4 weeks and every 90 days thereafter the Oxygen content remains below one percent (1%). An increase in the oxygen content indicates that purging of the tank is required. (See Topic: TANK PURGING)

THREE STAGE PRESSURE REDUCER ADJUSTMENTS

The three stage pressure reducer assembly regulates the flow of gas from the supply cylinder to the transformer tank. Stage one reduces the pressure of the gas flowing from the supply cylinder from 2200 to 100 psi.

Stage two further reduces the pressure of the flowing gas. The regulator at stage two reduces the pressure of the gas flowing from 100 to 7 psi.

The third stage reduces the pressure of the gas flowing from 7 to 0.5 psi and controls the flow of gas to the tank, admitting gas into the tank whenever the tank pressure drops below 0.5 psi. The three stages are factory set. The third stage also includes a relief valve which opens if tank pressure rises beyond 5.0 psi.

TANK PRESSURE ALARM SETTINGS

The compound pressure gauge monitors the gas pressure in the tank. The gauge is graduated from 15.0 psi negative to 15.0 psi positive (-15.0 psi to +15.0 psi). The gauge is equipped with two sets of alarm contacts. The high pressure alarm contacts are energized when tank pressure exceeds 5.5 psi; the low pressure alarm contacts are energized when tank pressure drops below 0.2 psi.

Transformer Nitrogen Systems Universal Instructions

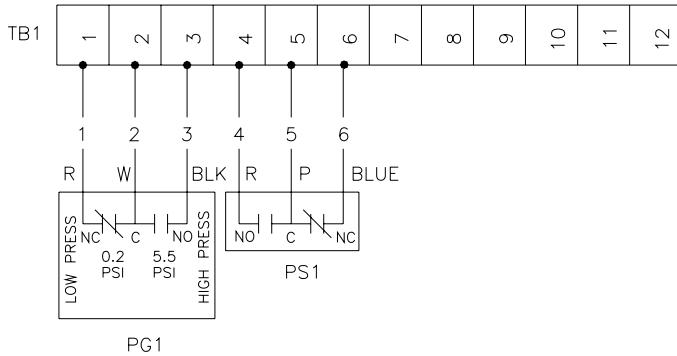

Figure 1 – Typical Alarm connections for pressure gauge (PG1) and bottle pressure switch (PS1)

NOTE: PG1 Switch contacts shown are in deactivated state – Contacts are open when tank pressure is between .2 and 5.5 psi. PSI contacts are shown in deactivated state (zero bottle pressure)

NITROGEN GAS CYLINDER REPLACEMENT

The cylinder that should be used is a standard, commercially available 244 cu. ft. nitrogen gas cylinder pressurized to 2000 psi. Replacement cylinders should meet all required pressure vessel specifications and be filled with oil pumped nitrogen or nitrogen with a certified moisture content of less than 0.03 percent by weight. The impurity content must be less than 7.5 parts per million.

Nitrogen consumption is dependent on transformer load variations and on the condition of the gas pressurizing equipment. Cylinder must be replaced when the supply pressure gauge reads 200 psi or below.

TO REPLACE THE CYLINDER

1. Close transformer inlet valve.
2. Close the supply cylinder shutoff valve.
3. Release the union connection and remove the empty cylinder.
4. Position the replacement cylinder and make the connection. Do not tighten more than finger tight.

5. Open the shut-off valve on the replacement cylinder very slightly. Allow the escaping gas to leak past the loose union connection and blow away any loose dirt; then tighten the connection with a wrench until leakage stops.

6. Open transformer inlet valve.

TANK PURGING

The nitrogen gas pressurizing system may be used to purge transformer tanks of contaminated gas or air. During purging, gas does not flow through the 3rd stage pressure regulator. Instead the gas flows from the 2nd stage regulator through a bypass line directly to the tank inlet pipe.

To Purge The Tank

1. Open the transformer outlet purge valve.
2. Turn the “By-Pass-Reg.” to “By-Pass” position for purging, this increases pressure going into the transformer from 0.5 to 7 psi.

When Purging Is Completed

1. Return the “By-Pass-Reg.” valve to “Reg.” position.
2. Close the transformer outlet purge valve.

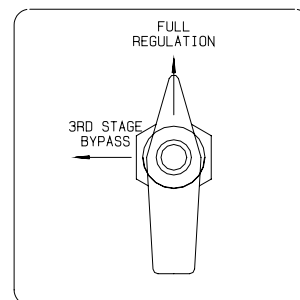

Figure 2 – Third stage regulation bypass valve

Transformer Nitrogen Systems Universal Instructions

INSTALLATION

The Nitrogen system is easy to install and maintain. The following should be noted during installation:

- Mount the cabinet so that the bottom is at least 4" above grade.
- Use 3/8" diameter mounting hardware to mount the cabinet securely to the side of transformer,
- Use sealed fittings for the electrical connections to avoid water accumulation inside the enclosure. Electrical connection points are provided on either side of the box and are sized for standard 1/2" conduit fittings.
- Ensure piping to the transformer is clean and free from corrosion or rust. The N2 system is designed to accept 1/4 NPT female connections for both the transformer tank inlet (left side of cabinet) and outlet (right side of cabinet) points. Valves located inside the cabinet walls allow the user to control the Inlet and outlet flow for the tank piping.

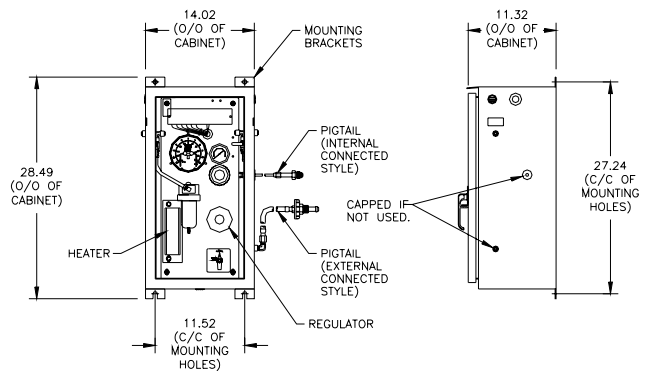

N2-0 System (external bottle)

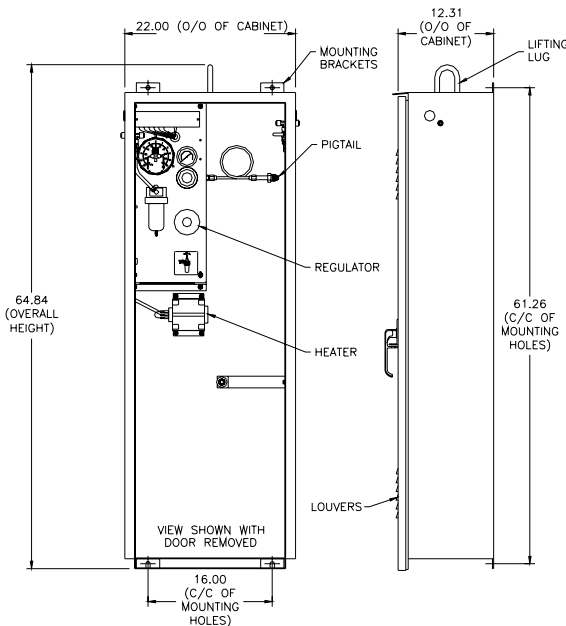

N2-1 System (One internal bottle)

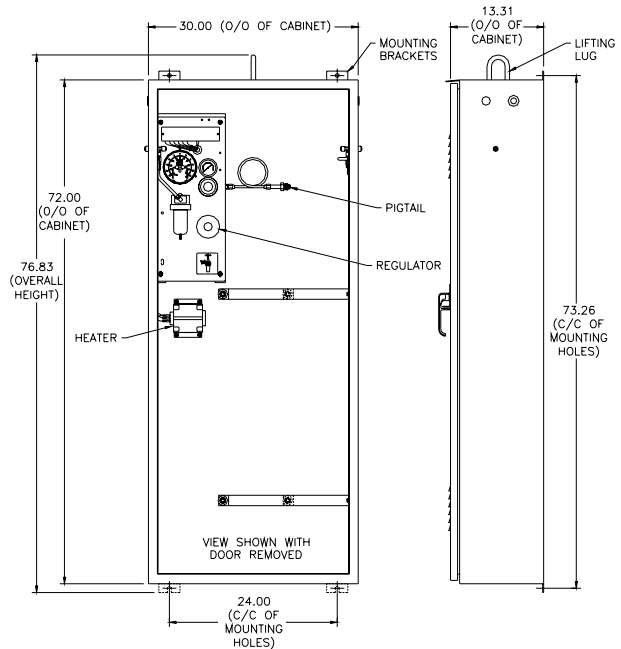

N2-2 System (Two internal bottles)



Transformer Nitrogen Systems Universal Instructions

HEATER POWER CONNECTIONS

The heaters for the N2 systems are the PTC self regulating type. Heater power requirements are 120V AC (50-60 Hz) and should be powered with a standard 20A feed.

N2-0 systems use a standard 50 Watt radiant heater type while the N2-1 and N2-2 systems use a 200 Watt forced convection type heater.

A terminal block is provided for easy customer power termination:

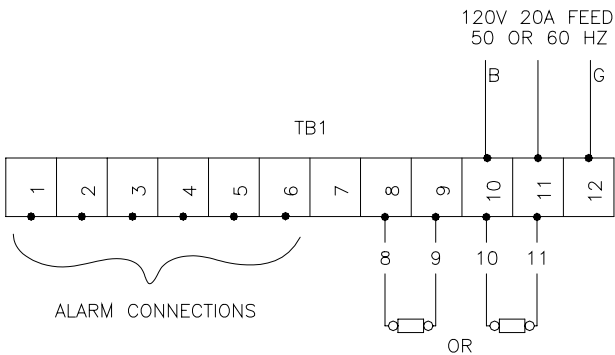

Figure 3 – Typical power connections for N2 system heaters.

REPLACEMENT PARTS AND SERVICE

Please contact High Voltage Supply at 800-338-5526 for replacement parts and/or service.